

SANNE
LIGHTING DESIGN

LP-SC-SS /// Light Painting - Straight Collection - Suspension

TECHNIEK

Fitting : Encapsulite - Stick light
Lamp : T8 fluorescentie tube
Kleur temperatuur : Warm wit 2 700K
Spanning : 230V
Ballast : Geïntegreerd
Dimbaar : Ja
Materialen : Epoxy met pigment of digitale print op plexiglas, aluminium
Afmeting : Breedte 14cm, Hoogte 17cm

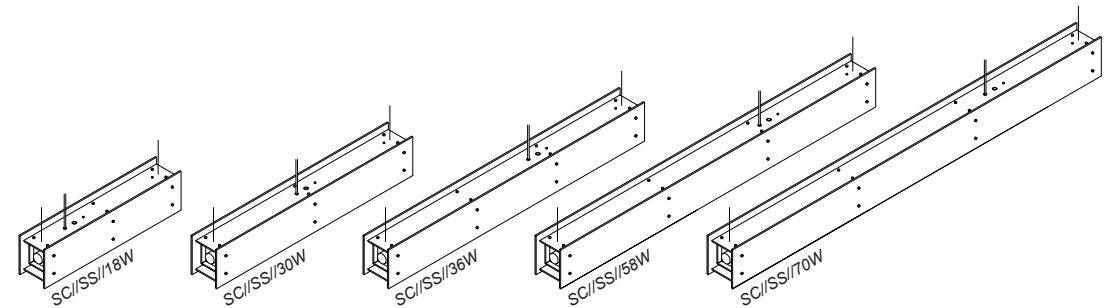

LENGTE (cm)	VERMOGEN
187	70 W
160	58 W
130	36 W
100	30 W
70	18 W